

### PRODUCT DESCRIPTION

The TRUFAST Aluminum Retrofit Roof Drain with sealant tape features a 2" (51 mm)-wide band of high density, expanding foam tape impregnated with asphalt that is factory applied in a compressed state around the drain outlet.

Sealant tape is designed to expand to approximately four times its compressed thickness. Just prior to inserting the drain, the installer removes the exterior compression tape and immediately sets the retrofit drain in place. The released tape gradually expands to fill the space between the TRUFAST drain and the existing drain sleeve, making the connection watertight.

TRUFAST sealant tape expands more slowly in cold temperatures. When heat is applied to the inside of the outlet, the sealant tape expands more rapidly. Should the tape expand too much before inserting the TRUFAST drain, simply recompress the tape by hand and then insert the drain.

**Features include:**

- Aluminum retrofit drain with aluminum body, available in dia. sizes: 2", 3", 4", 5", 6" or 8"
- Constructed of heavy duty spun aluminum
- Seals securely within existing pipe
- Prevents water back-up problems by sealing side wall gaps with expandable waterproof tape
- Drain outlet length: 12"
- Available with Aluminum or PVC strainer
- Simple and quick to install

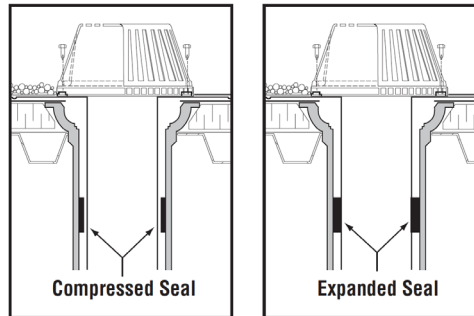

### DRAIN SEAL

TRUFAST aluminum drains are an economical answer to potential water back-up problems. They are designed to fit neatly into old existing drains in a retrofit application.

### PRODUCT SELECTION: Aluminum Retrofit Drains with Sealant Tape Termination & Aluminum Strainer

Part No.	Drain Diameter		Clamping Ring	Strainer	Pkg. Wt.	Pallet Qty.
RD-2000-AL-ASCR	2"	50.8 mm	Aluminum	10" Aluminum	12 lbs.	36
RD-2000-AL-ASCRT	2"	50.8 mm	TPO Flange Coating	10" Aluminum	12 lbs.	36
RD-2000-AL-ASCRP	2"	50.8 mm	PVC Flange Coating	10" Aluminum	12 lbs.	36
RD-3000-AL-ASCR	3"	76.2 mm	Aluminum	10" Aluminum	12 lbs.	36
RD-3000-AL-ASCRT	3"	76.2 mm	TPO Flange Coating	10" Aluminum	12 lbs.	36
RD-3000-AL-ASCRP	3"	76.2 mm	PVC Flange Coating	10" Aluminum	12 lbs.	36
RD-4000-AL-ASCR	4"	101.6 mm	Aluminum	10" Aluminum	14 lbs.	36
RD-4000-AL-ASCRT	4"	101.6 mm	TPO Flange Coating	10" Aluminum	14 lbs.	36
RD-4000-AL-ASCRP	4"	101.6 mm	PVC Flange Coating	10" Aluminum	14 lbs.	36
RD-5000-AL-ASCR	5"	152.4 mm	Aluminum	10" Aluminum	10 lbs.	36
RD-5000-AL-ASCRT	5"	152.4 mm	TPO Flange Coating	10" Aluminum	10 lbs.	36
RD-5000-AL-ASCRP	5"	152.4 mm	PVC Flange Coating	10" Aluminum	10 lbs.	36
RD-6000-AL-ASCR	6"	152.4 mm	Aluminum	10" Aluminum	18 lbs.	36
RD-6000-AL-ASCRT	6"	152.4 mm	TPO Flange Coating	10" Aluminum	18 lbs.	36
RD-6000-AL-ASCRP	6"	152.4 mm	PVC Flange Coating	10" Aluminum	18 lbs.	36
RD-8000-AL-ASCR	8"	203.2 mm	Aluminum	10" Aluminum	12 lbs.	36
RD-8000-AL-ASCRT	8"	203.2 mm	TPO Flange Coating	10" Aluminum	12 lbs.	36
RD-8000-AL-ASCRP	8"	203.2 mm	PVC Flange Coating	10" Aluminum	12 lbs.	36

### PRODUCT SELECTION: Aluminum Retrofit Drains with Sealant Tape Termination & PVC Strainer

Part No.	Drain Diameter		Clamping Ring	Strainer	Pkg. Wt.	Pallet Qty.
RD-2000-AL	2"	50.8 mm	Aluminum	10" Plastic	6 lbs.	36
RD-2000-AL-TPO	2"	50.8 mm	TPO Flange Coating	10" Plastic	6 lbs.	36
RD-2000-AL-PVC	2"	50.8 mm	PVC Flange Coating	10" Plastic	6 lbs.	36
RD-3000-AL	3"	76.2 mm	Aluminum	10" Plastic	6 lbs.	36
RD-3000-AL-TPO	3"	76.2 mm	TPO Flange Coating	10" Plastic	6 lbs.	36
RD-3000-AL-PVC	3"	76.2 mm	PVC Flange Coating	10" Plastic	6 lbs.	36
RD-4000-AL	4"	101.6 mm	Aluminum	10" Plastic	6 lbs.	36
RD-4000-AL-TPO	4"	101.6 mm	TPO Flange Coating	10" Plastic	6 lbs.	36
RD-4000-AL-PVC	4"	101.6 mm	PVC Flange Coating	10" Plastic	6 lbs.	36
RD-5000-AL	5"	127 mm	Aluminum	10" Plastic	6 lbs.	36
RD-5000-AL-TPO	5"	127 mm	TPO Flange Coating	10" Plastic	6 lbs.	36
RD-5000-AL-PVC	5"	127 mm	PVC Flange Coating	10" Plastic	6 lbs.	36
RD-6000-AL	6"	152.4 mm	Aluminum	10" Plastic	6 lbs.	36
RD-6000-AL-TPO	6"	152.4 mm	TPO Flange Coating	10" Plastic	6 lbs.	36
RD-6000-AL-PVC	6"	152.4 mm	PVC Flange Coating	10" Plastic	6 lbs.	36

### AVAILABLE UPGRADES:

Part No.	Description	Pkg. Wt.	Pallet Qty.
RD-10000-CI-S	10" Cast Iron Strainer	7 lbs.	NA
RD-10000-CI-SCR	10" Cast Iron Strainer & Clamping Ring	8.3 lbs.	NA
RD-10000-AL-SCR	10" Aluminum Strainer & Clamping Ring	4 lbs.	NA



### INSTALLATION GUIDELINES

**Step 1:** Inspect the old drain for possible cracks and for a smooth, clean surface. Scrape away old asphalt and dirt. Use a heat gun to soften old asphalt and to achieve a relatively dry surface, if necessary.

**Step 2:** Test the size of the new TRUFAST aluminum drain by inserting it into the now-clean, original drain before removing the compression tape. With the correct size confirmed, remove the drain, release the compression tape and

promptly re-insert the TRUFAST drain. The tape gradually expands to fill the space surrounding the outlet of the new drain, thereby creating the back-up seal feature.

**Step 3:** Flash in the drain flange according to methods determined by the membrane manufacturer and/or the roofer using the clamping ring (CR), if applicable. Attach the strainer dome.

Bulletin No. TF-25091

### DISCLAIMER

The information provided here is subject to change without notice. The performance specifications published in this TRUFAST<sup>®</sup> product literature are based on controlled laboratory tests and are intended as a guideline only. They are not guaranteed in any way by the ALTENLOH, BRINCK & CO. US, INC., since building design, engineering, and construction, including workmanship and

materials, are beyond the control of the manufacturer. For TRUFAST fasteners, the manufacturer recommends that pull-out tests be conducted to verify the substrate provides adequate pull-out values.